

# **Juicelady**<sup>®</sup>

JL500

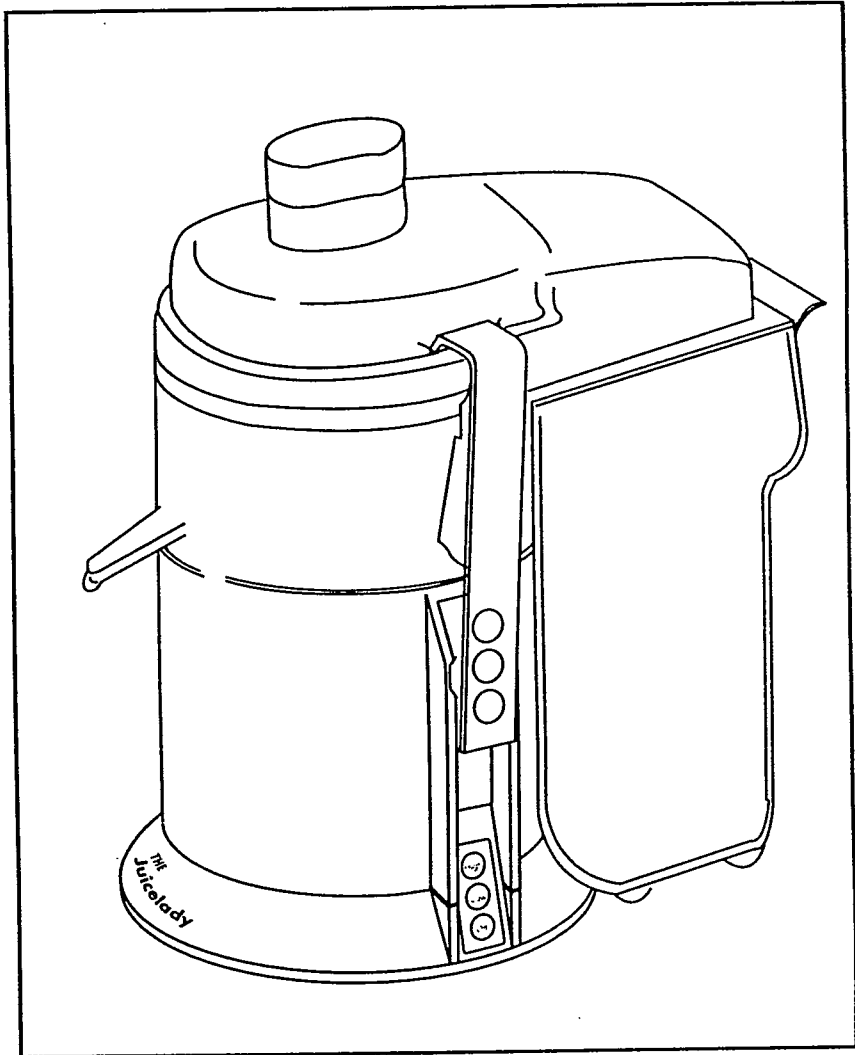

INSTRUCTION MANUAL



You will be delighted to have the Juicelady® JL500 as the newest item in your healthful kitchen! We are proud to bring you another product that makes delicious, healthy eating so easy.

Did you know that the USDA, the Surgeon General, the National Cancer Institute, and the Secretary of Health and Human Services all recommend eating a minimum of 2-4 servings of fresh fruits and 3-5 servings of fresh vegetables every day? Juicing some of these recommended servings provides a convenient alternative to eating all your fruits and vegetables whole.

Fresh juice is an important part of a healthy diet, providing vitamins, minerals, water, proteins, carbohydrates, and chlorophyll. Juicing is a great way to provide your children with fruits and vegetables they may not normally eat. After a workout, it's a great, no-fat way to replenish electrolytes lost through sweating. Juice is also a quick, nutritious snack—and for people with little time or who are watching their weight, it's a light, low-calorie meal.

The Juicelady® JL500 introduces several new features that will make juicing even more convenient! You can now select either high speed for harder produce, or low speed for softer produce. This will ensure maximum juicing efficiency—which means you will get the most juice possible from each piece of produce that you juice. As well, you can choose a right-hand or left-hand assembly for added comfort during juicing. The JL500 also offers enhanced safety features and a new control panel design that protects buttons from moisture.

For great recipe ideas and juicing tips, see the enclosed *Fresh Juice Recipes & Menu Planner*.

To Your Good Health!

Juicelady® Health Products

p.s. If, after reading this instruction booklet, you still have questions about using the Juicelady® JL500, please write: **Juicelady® Health Products**, 550 Business Center Drive, Mt. Prospect, IL 60056. Or, call: (800) 233-9054, Monday-Friday, 8 AM - 5PM CST.



---

# IMPORTANT SAFEGUARDS

When using electrical appliances, basic safety precautions should always be followed, including the following:

1. Read all instructions carefully.
2. To protect against risk of electrical shock, do not rinse or immerse Motor Base in water or other liquid.
3. Close supervision is necessary when any appliance is used by or near children.
4. Unplug from outlet when not in use, before putting on or taking off parts, and before cleaning.
5. Avoid contacting moving parts.
6. Always make sure Lid is clamped securely in place before motor is turned on. Do not unfasten Clamps while Juicer is in operation.
7. Never operate without Pulp Collector in place.
8. Be sure to press "OFF" Button (on Control Panel) after each use of your appliance. Make sure the motor stops completely before disassembling.
9. Do not put your fingers or other objects into the appliance opening while it is operating. Never feed food by hand — always use the Food Pusher. If food becomes lodged in the opening, use the Food Pusher to push it down. When this method is not possible, turn the motor off and disassemble Juicer to remove the remaining food.
10. Do not operate any appliance with a damaged cord set or after the appliance malfunctions, or is dropped or damaged in any manner. Return the appliance to the manufacturer for examination, repair or electrical or mechanical adjustment.
11. The use of attachments not recommended or sold by the manufacturer may cause fire, electrical shock or injury.
12. Do not use outdoors.
13. Do not let cord hang over edge of table or counter or touch hot surfaces.
14. Do not leave the appliance unattended while it is operating.
15. Blades are sharp. Handle carefully.

**SAVE THESE INSTRUCTIONS**  
**FOR HOUSEHOLD USE ONLY**



# YOUR JUICELADY® JL500

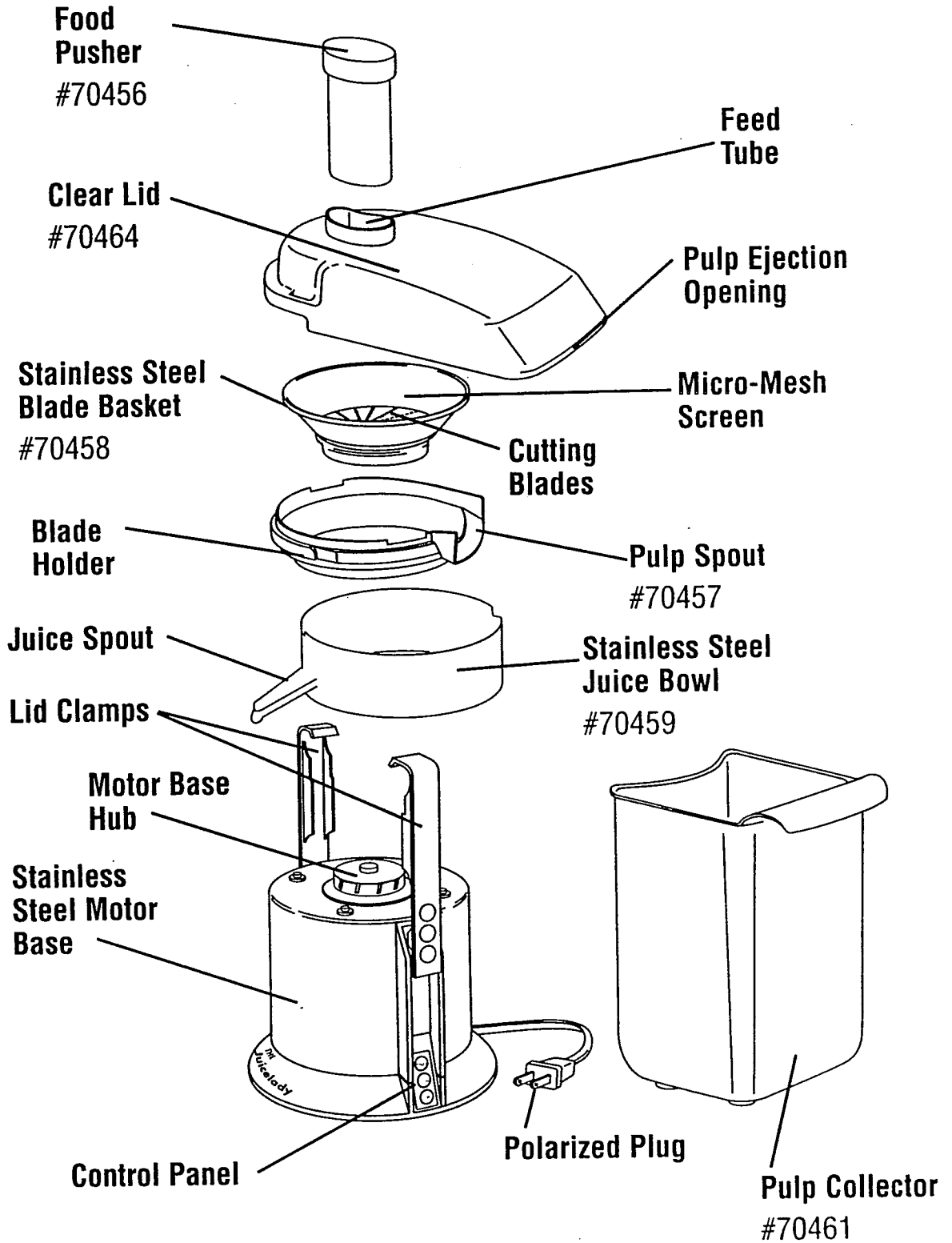



## YOUR JUICELADY® JL500 (Continued)

Your Juicelady® JL500 has a unique Control Panel which offers two speed options—High and Low. This provides maximum efficiency by allowing you to choose the speed at which the Blade Basket will turn and ultimately produce the most juice.

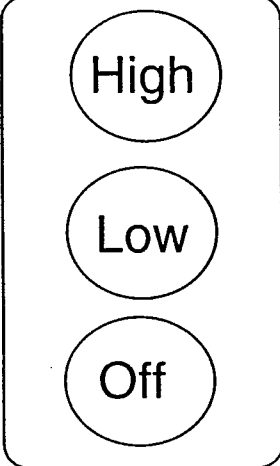
|  |  |                   |
|--|--|-------------------|
|  | Best for <b>harder produce</b> —carrots, beets, and pineapple (with rind). Also recommended for leafy or stringy produce such as celery and greens.                      | <b>HIGH SPEED</b> |
|  | Best for <b>softer produce</b> —citrus, apples, grapes (with stems), melons, peaches (remove pit), and tomatoes. Also recommended for ripe produce that has become soft. | <b>LOW SPEED</b>  |
|  | Press this button to turn your Juicelady® JL500 <b>off</b> .   | <b>OFF</b>        |

## CONSUMER SAFETY INFORMATION

### POLARIZED PLUG

This appliance has a **polarized plug** (one blade is wider than the other). As a safety feature, this plug fits in a polarized outlet only one way. If the plug does not fit into the outlet, reverse the plug and try again. If it still does not fit, contact a qualified electrician. Do not attempt to modify the plug in any way.

### SHORT CORD INSTRUCTIONS

A **short power-supply cord** is provided to reduce the risk resulting from becoming entangled in or tripping over a longer cord. Longer extension cords are available and may be used if care is exercised in their use.

If an extension cord is used, (1) the marked electrical rating of the extension cord should be at least as great as the electrical rating of the appliance, and (2) the longer cord should be arranged so that it will not drape over the counter top or table where it can be pulled on by children or tripped over unintentionally.



## BEFORE USING YOUR JUICELADY® JL500

Your Juicelady® JL500 comes almost completely assembled in the box. We suggest taking it apart (see "DISASSEMBLY") and washing the removable parts in warm water with a biodegradable, non-abrasive liquid detergent before first use. (See "CLEANING YOUR JUICER.") This will eliminate any traces of dust or residue from manufacturing or shipping.

**NOTE:** Your Juicer may be shipped with a protective cardboard insert between the Feed Tube and Cutting Blades (on the Blade Basket). Remove this and any other protective packaging before using your Juicer.

**CAUTION:** *Never rinse or immerse the Motor Base in water or any other liquid.*

**NOTE:** Refer to the *Fresh Juice Recipes & Menu Planner* for juice recipes, pulp recipes, sample menus, and tips on buying, cleaning and storing produce.

### **Preparing fruits and vegetables for your juicer**

- Use a natural bristle brush to clean all produce thoroughly. If you are not using organic produce, we recommend using a biodegradable cleaner to help remove pesticide residue.
- Remove and discard the outer leaves of non-organic produce and peel any waxed fruit or vegetable.
- Trim away any discolored or bruised sections.
- The skin may be left on all produce (including pineapple and melons) except oranges, grapefruit, and tangerines. However, the oil found in these skins tastes bitter and is difficult to digest.
- Remove melon seeds when possible, as they may escape through the top of the feed tube while juicing. Remove the pits of fruits such as cherries, pears, and peaches.
- Cut produce into pieces small enough to fit into the Feed Tube. Use the Food Pusher to gently direct produce through the Feed Tube.  
*Never push produce into the feed tube with your fingers.*
- Bunch up leafy greens, parsley, wheat grass, and sprouts into a small, tight ball and push through with a carrot or the Food Pusher.
- Bananas are not suitable for juicing; a clear juice cannot be obtained from them and residue left in the machine can clog the Micro-Mesh Screen. For best results, produce such as apricots, plums, pears, peaches, and tomatoes should be firm when juicing.



## DISASSEMBLY INSTRUCTIONS

### Step One—Remove Clamps

Place thumb onto center dot on Clamp and place fingers under bottom of Clamp. Pull bottom of Clamp out and push Clamp up. Allow top of Clamp to swing out. Repeat for opposite Clamp.

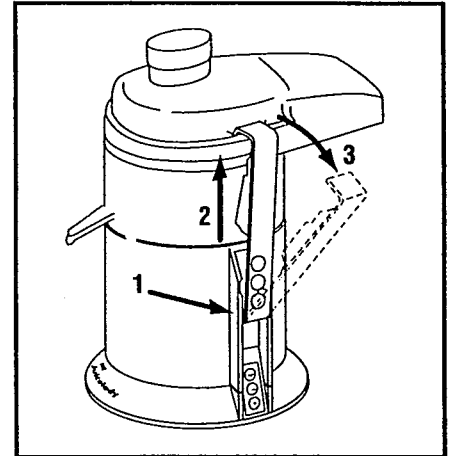

### Step Two—Remove Juice Bowl Assembly

Grasp the sides of the Stainless Steel Juice Bowl. Carefully lift off the Stainless Steel Juice Bowl, Clear Blade Holder, Blade Basket, and Clear Lid as one piece. These pieces will then come apart for easy cleaning. (See "CLEANING YOUR JUICER" for cleaning instructions.)

**CAUTION:** Use care when handling Blade Basket; the Cutting Blades are very sharp!

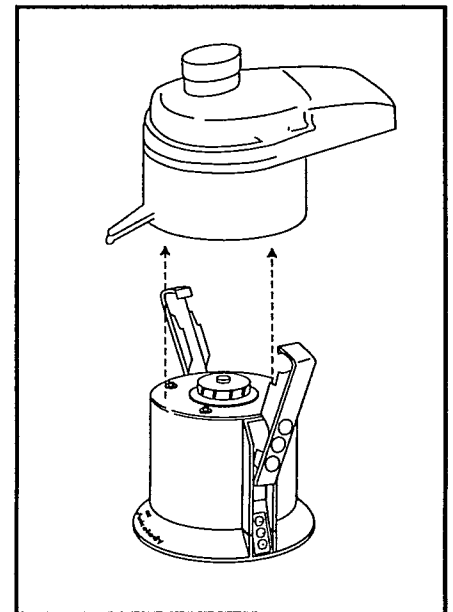



## ASSEMBLY INSTRUCTIONS

**NOTE:** For your juicing convenience, your Juicelady® JL500 can be assembled for right-hand or left-hand use. Right hand use allows the user to place the produce into the Feed Tube with the left hand while operating the Food Pusher with the right hand. If you are left-handed, or feel the juicing operation is uncomfortable, you can reverse the assembly instructions below so the Juice Spout is to the rear of the unit (and all subsequent parts will face the opposite way).

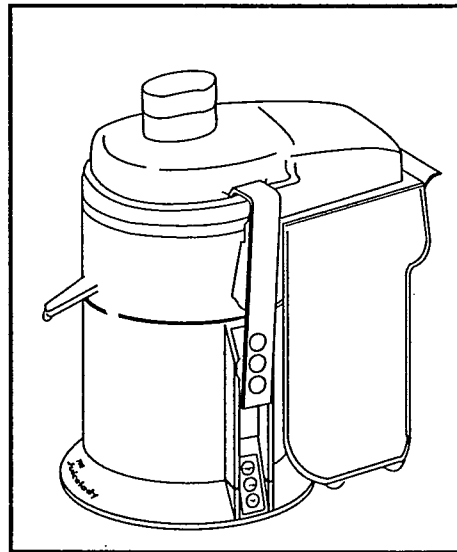

*Right Hand Assembly*

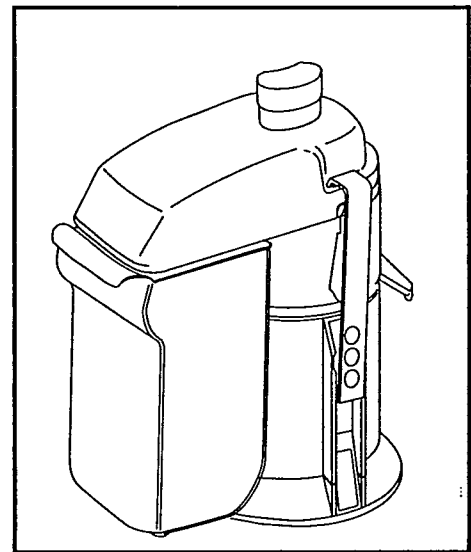

*Left Hand Assembly*

### **Step One—Place Juice Bowl**

Place Juice Bowl on top of Motor Base so Juice Spout is to the front (over the Juicelady logo). Align four tabs on underside of Juice Bowl with four buttons on Motor Base. Lower Juice Bowl onto Base and rotate slightly to fit tabs over buttons.

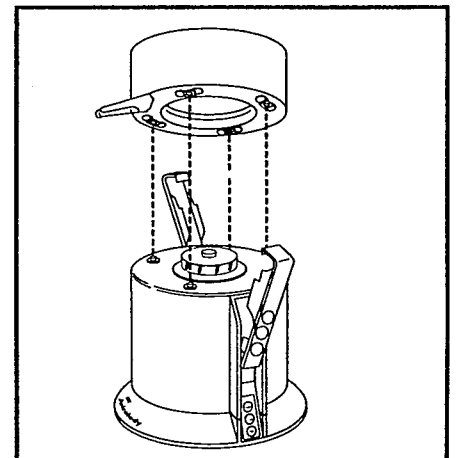





## ASSEMBLY INSTRUCTIONS (Continued)

### Step Two—Place Blade Holder

Place Blade Holder on top of Juice Bowl so Pulp Spout is opposite Juice Spout. Align square tab on underside rim of Blade Holder with bend in rim of Juice Bowl. When seated properly, the Blade Holder will turn only slightly.

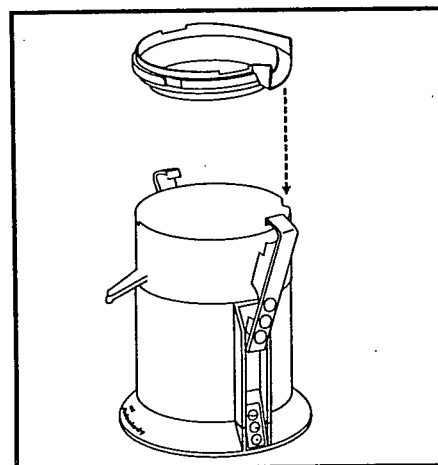

### Step Three—Place Blade Basket

Grasp Blade Basket around top rim with both hands and center Basket over Hub on Motor Housing. Carefully lower Blade Basket onto Hub and rotate slightly until it drops into position and is seated properly. (When seated properly, the Blade Basket will not lift out of the Blade Holder and will spin freely.)

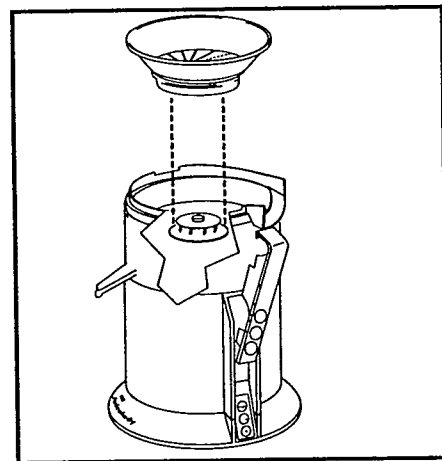

**CAUTION:** Use care when handling Blade Basket; the Cutting Blades are very sharp!

### Step Four—Place Clear Lid

Align Clear Lid so Pulp Ejection Opening is over Pulp Spout. Place the cut-outs in the Clear Lid over the matching cut-outs in the rim of the Blade Holder.

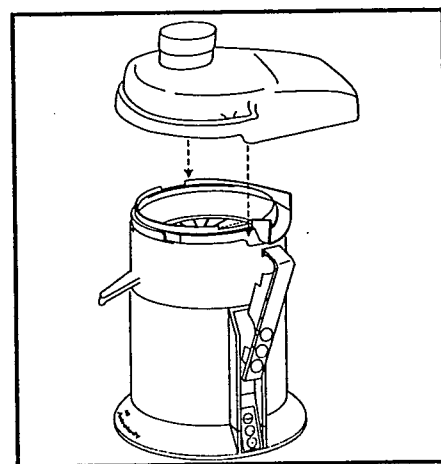



## ASSEMBLY INSTRUCTIONS (Continued)

### Step Five—Attach Clamps

While holding Clamp from the bottom, push Clamp up and in until top of Clamp rests in slot on the Clear Lid. Place thumb onto center dot on Clamp and firmly press in until the bottom of the Clamp snaps into place. Repeat for opposite Clamp.

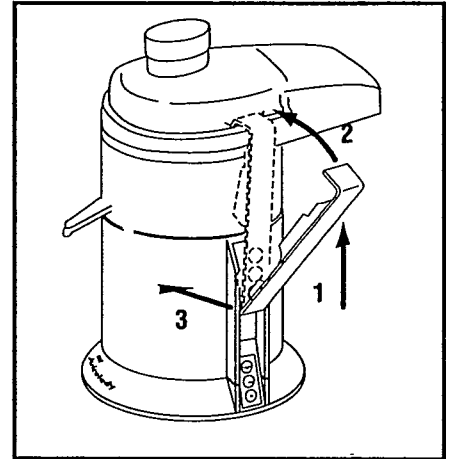

### Step Six—Place Pulp Collector

Place the Pulp Collector under the Pulp Ejection Opening on the Clear Lid. The Pulp Collector will fit snugly against the edge of the Juicer.

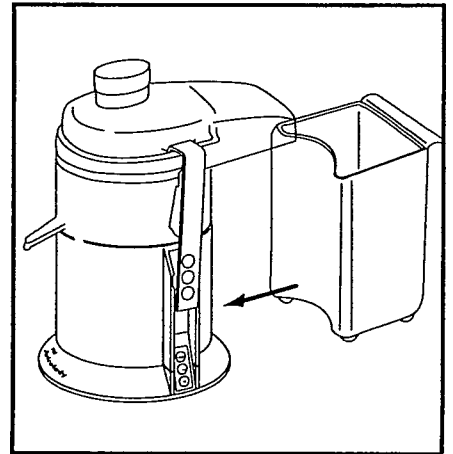



## USING THE JUICELADY® JL500

### To turn your Juicelady® JL500 on:

- Make sure that your Juicer is completely and properly assembled. See "ASSEMBLY INSTRUCTIONS." **The Juicer will not turn on unless properly assembled.**
- Make sure the Blade Basket is securely seated and the Pulp Collector is at the rear of the Juicer, ready to catch pulp. To save cleaning time, line the Pulp Collector with a plastic produce bag (the kind you put your produce in at the grocery store).
- Place a glass underneath the Juice Spout.
- Remove the Food Pusher from the Feed Tube.
- Plug the Juicelady® into a standard, 120V AC household electrical outlet.
- Press "HIGH" speed button for harder produce.
- Press "LOW" speed button for softer produce.
- Place produce into the Feed Tube and gently direct through the Feed Tube and Blade Basket with the Food Pusher.
- When juicing a combination of hard and soft produce, such as carrots and apples, you will want to use high speed for the carrots and low speed for the apples. You do not have to turn the machine off to change speeds. Simply press the appropriate speed button for each type of produce being juiced.

*Tip: Try alternating types of produce to ensure maximum efficiency.*

### To turn your Juicelady® JL500 off:

- Press "OFF" Button.
- Unplug Juicelady® from wall outlet after each use.

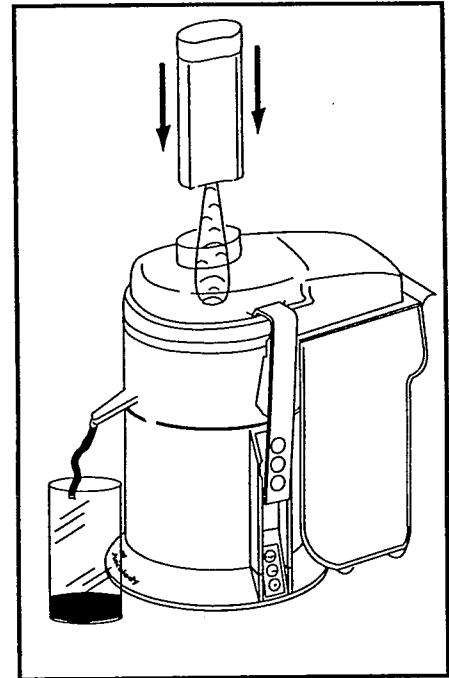



## CLEANING YOUR JUICER

**CAUTION:**

**Do not immerse the motor base in water or spray it with water. Clean only by wiping with a damp sponge, cloth, or paper towel.**

- All parts (except the Motor Base) are washable in warm, soapy water. Disassemble according to "DISASSEMBLY" instructions. To clean the Lid and Juice Bowl, we recommend using a fruit and vegetable brush with natural fibers. **DO NOT USE A METAL BRUSH OR PAD.**

- When cleaning the Blade Basket, use the brush to make sure the tiny holes in the basket are not clogged. This can be accomplished by holding the Blade Basket under a running faucet while brushing the Basket holes from both inside and outside the Blade Basket.

**PLEASE NOTE:**

- Occasionally, the Juice Bowl, Lid, and Blade Basket may be washed in a dishwasher, **only if** they are placed on the **top shelf** of the dishwasher. However, washing with ordinary warm (not hot) tap water on a daily basis should be sufficient.
- Sponge off the Motor Base and the Legs underneath if any juice has spilled under the Juicer. Use a damp toothbrush or cloth to clean juice from inside the Hub on top of the Motor Base.

### **Juicer should be air-dried only!**

**Clean Your Juicer Thoroughly Before Retiring For The Day**

Due to the powerful staining properties of the carotenoids that are found in many vegetables, especially carrots, we suggest the following cleaning procedures:

- Stained parts may be soaked overnight in any of these solutions: (1) biodegradable soap in enough warm water to cover juicer parts, (2) 1/4 cup bleach to sink full of warm water, (3) 1 part warm water to 1 part cider vinegar or (4) 1/2 small box baking soda in enough warm water to cover parts.
- Never use ammonia or abrasives.
- Lightly scrub with soft bristle brush and liquid detergent after soaking.
- **NEVER RINSE OR IMMERSE THE MOTOR BASE IN WATER OR OTHER LIQUID!**

**Any other servicing should be performed by authorized personnel only**



---

---

## TROUBLESHOOTING

| Symptom   | Possible Correction   |
|---|---|
| Pulp builds up excessively in the back of the Lid.  | Try juicing slower, as wet produce is more likely to build up in Lid. To release pulp, lightly tap on the side of the Lid. Empty Pulp Collector if full.  |
| Bottom of Feed Tube is damaged.   | Blade Basket may not have been seated correctly, causing it to become unseated during use. Should this be the case, check the Gear Teeth of the Blade Basket and the Motor Base for damage.   |
| Blade Basket is difficult to: <ul style="list-style-type: none"><li>•insert onto Hub;</li><li>•remove from Hub.</li></ul> | Snug seating is desirable. To insert, try seating the Blade Basket on a different Hub position. To remove, lift Blade Holder with Blade Basket from Motor Base.   |
| Too much pulp builds up on Blade Basket.  | This may be an isolated situation resulting from the varied texture and moisture content of the produce. Stop juicing, scrape off pulp and begin again, alternating types of produce.   |
| Excessive noise or vibrations occur after Juicer is turned on.  | Pulp may have built up on the Blade Basket. Clean the Blade Basket and try alternating different types of produce while juicing.<br><b>Note:</b> Because of the Juicelady®'s powerful motor, a small amount of noise and/or vibration is normal when the Juicer is turned on and as it comes to a complete stop. All Juicers will sound slightly different. |
| Juice sprays out of the Spout.  | Juice the produce as slowly as possible. Keep the Pulp Collector emptied for good air flow through machine.   |
| Juice leaks between Juice Bowl and Lid.   | Juice slowly so that the Blade Basket chamber does not fill up too quickly with juice. Keep Pulp Collector emptied to allow good air flow through the machine.  |
| Pulp in juice.  | Juice slowly to avoid excessive pulp buildup inside the Lid and Juice Bowl.   |



---

## TROUBLESHOOTING (Continued)

| <b>Symptom</b>   | <b>Possible Correction</b>  |
|--|---|
| <b>Inside rim of Juice Bowl is worn or chipped (inside lower rim or inside upper rim).</b> | Improper fit between the Blade Basket and Hub can cause parts of the Juice Bowl to rub against the Blade Basket.  |
| <b>Wet pulp.</b>   | Juicer at low speed setting. Certain produce (pineapples and overripe produce) may build up on Blade Basket, causing pulp to eject before juice is completely extracted. Fruit tends to produce wetter pulp than vegetables. If problem persists, rinse Blade Basket. |
| <b>Juicer stopped while juicing.</b>   | Try a different wall outlet. Also let Juicer sit for about an hour without turning it on; moisture may have collected on the circuit board, causing machine to shut off.  |
| <b>Juicer does not turn on.</b>  | Try a different wall outlet. Also, try using both the "HIGH" and "LOW" Speed Buttons. Check the Lid, Blade Basket, and Juice Bowl to see if they are properly seated.   |

---

**NOTE:** If none of these troubleshooting solutions work for you, discontinue use of your juicer and contact our consumer service department at (800) 233-9054.

# ONE-YEAR LIMITED WARRANTY

This Juicelady® product warranty extends to the original consumer purchaser of the product.

**Warranty Duration:** This product is warranted to the original consumer purchaser for a period of one (1) year from the original purchase date.

**Warranty Coverage:** This product is warranted against defective materials or workmanship. This warranty is void if the product has been damaged by accident, in shipment, unreasonable use, misuse, neglect, improper service, commercial use, repairs by unauthorized personnel or other causes not arising out of defects in materials or workmanship. This warranty is effective only if the product is purchased and operated in the USA and Canada, and does not extend to any units which have been used in violation of written instructions furnished by Juicelady® or to units which have been altered or modified or to damage to products or parts thereof which have had the serial number removed, altered, defaced or rendered illegible.

**Warranty Disclaimers:** This warranty is in lieu of all warranties expressed or implied and no representative or person is authorized to assume for Juicelady® any other liability in connection with the sale of our products. There shall be no claims for defects or failure under any theory of tort, contract or commercial law including, but not limited to negligence, gross negligence, strict liability, breach of warranty and breach of contract.

**Warranty Performance:** During the above one-year warranty period, a product with a defect will be either repaired or replaced with a reconditioned comparable model (at Juicelady®'s option) when the product is returned to the Juicelady® facility. The repaired or replacement product will be in warranty for the balance of the one-year warranty period and an additional one-month period. No charge will be made for such repair or replacement.

## Service and Repair

Should the appliance malfunction, you should first call toll-free 1-800-233-9054 **between the hours of 8:00 am and 5:00 pm Central Standard Time** and ask for **CONSUMER SERVICE** stating that you are a consumer with a problem.

**In-Warranty Service:** For an appliance covered under the warranty period, no charge is made for service and return postage. Call for pre-paid return mailing label. (U.S. Customers Only)

**Out-of-Warranty Service:** A flat rate charge by model is made for Out-of-Warranty service. Please include \$8.00 (U.S.) for return shipping and handling.

Juicelady® cannot assume responsibility for loss or damage during incoming shipment. For your protection, carefully package the product for shipment and insure it with the carrier. Be sure to enclose the following items with your appliance: any accessories related to your problem; your full name and return address and daytime phone number; a note describing your problem, a copy of your sales receipt or other proof of purchase to determine warranty status. C.O.D. shipments cannot be accepted.

Return the appliance to:

ATTN: Repair Department  
Juicelady®  
550 Business Center Drive  
Mt. Prospect, Illinois 60056

For more information on Juicelady® products visit our website:  
<http://www.juiceman.com>, or you can E-Mail us at: [juiceman@saltonusa.com](mailto:juiceman@saltonusa.com)